

Product description

Cooperate has developed a membrane contactor using PTFE hollow fiber membrane for efficient and cost-effective ammonia nitrogen removal.

Features and advantages

- Efficient removal of ammonia nitrogen-
- Operates at near-normal pressure with low energy consumption and minimal operating costs
- Providing corrosion resistance, high resistance to strong acids and alkalis, high-temperature resistance, strong hydrophobicity, and a long service life
- Possesses uniform pores and a narrow pore size distribution to prevent concentration polarization and scaling
- Strong resistance to fluid impact, eliminating the risk of broken fibers

Material

Components	Material
shell	UPVC
Membrane	PTFE
Sealing ring	EPMD
Potting	Epoxy resin

Specification

Membrane area	12m ²
Membrane pore size	0.1μm
Design water flow	50-150L/h
Design water inlet pressure	0.02-0.05MPa
Design water inlet temperature	35-45 °C
Design inlet water pH	> 11
Design acid inlet pressure	0.02-0.05MPa
Design acid inlet temperature	5-45°C
Design acid inlet pH	1-2

PTFE-TMCS-4040 Membrane Contactor

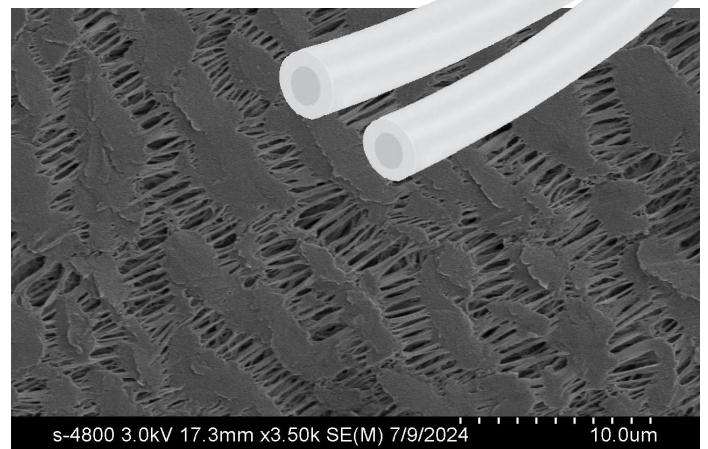
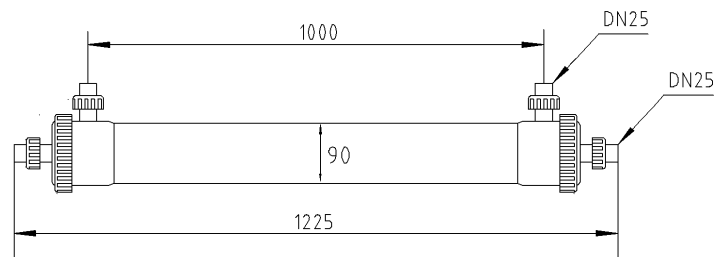
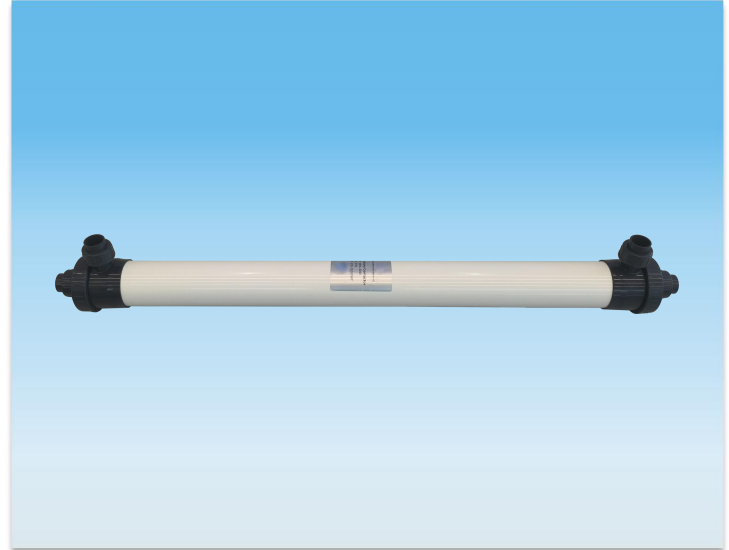

Membrane 3D drawing and 3000 times electron microscope image of the inner surface

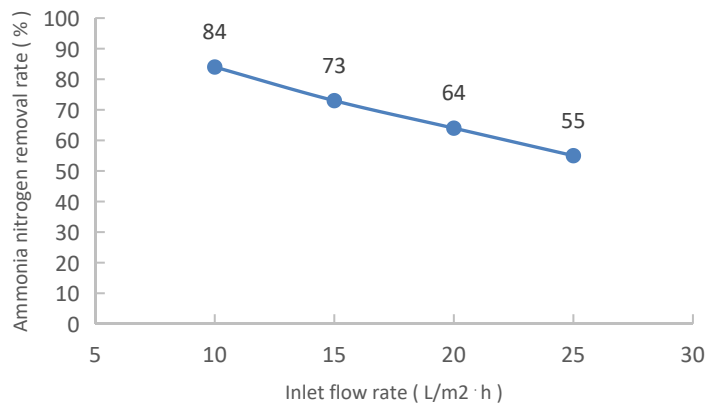

Note: The ammonia nitrogen content of the raw water is 2076ppm, pH=12.18, the raw water temperature is raised to 45°C, and the pH value of the sulfuric acid absorption liquid is maintained below 1. The above test data is the removed racial average level curve of ammonia nitrogen wastewater passing through the deammoniation membrane shell, and the individual deviation of the membrane contactor from the average level is within $\pm 3\%$.

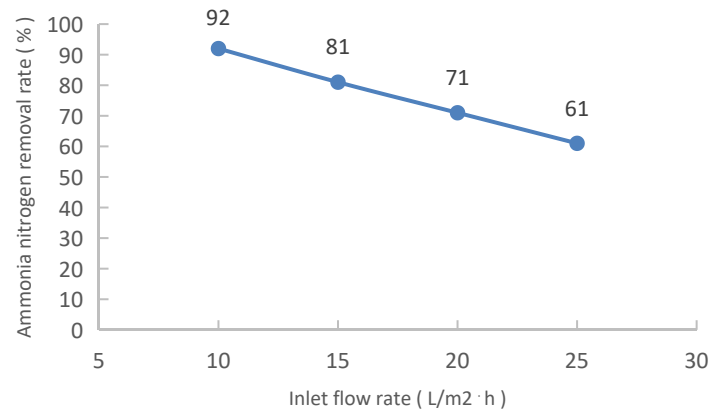

Note: The ammonia nitrogen content of the raw water is 2076ppm, pH=12.18, the raw water temperature is raised to 45°C, and the pH value of the sulfuric acid absorption liquid is maintained below 1. The above test data is the removed racial average level curve of ammonia nitrogen wastewater passing through the deammoniation membrane lumen side, and the individual deviation of the membrane contactor from the average level is within $\pm 3\%$.

Applications

- ◆ Removal of ammonia nitrogen from ternary precursor and semiconductor wastewater.
- ◆ Chemical, pharmaceutical, pesticide, metallurgy, municipal sewage, and landfill leachate.
- ◆ Extraction of bromine from seawater, concentrated seawater, underground brine, chemical feed liquid, etc.



Company Address: Building 17, Liandong U Valley Hefei High-tech International Enterprise Port, No. 2899 Kongquetai Road, Hefei High-tech Zone, Hefei, China

Please visit our website: www.coopmem.com